

**AVISON
YOUNG**

LISGAR
COMMERCIAL REAL ESTATE



1540
CORNWALL RD
OAKVILLE, ON

AVAILABLE
FOR LEASE
UP TO
4,522 SF

For more information, please contact:

Kurt Love, SIOR
Vice President, Sales Representative
905.283.2341
kurt.love@avisonyoung.com

 **BEST
MANAGED
COMPANIES**

Platinum member

1540
CORNWALL RD
OAKVILLE, ON

PROPERTY DETAILS.....

PRICING

\$16.50
Net psf

\$14.85
Additional psf
(2024 est.)

ZONING: Office

PROPERTY DETAILS

UNIT 108: 1,267 sf

UNIT 204: 4,522 sf

UNIT 211: 1,760 sf

UNIT 223: 850 sf

HIGHLIGHTS

- 4/1,000 sf free surface parking
- Public transit at door
- Property management on site
- Easy access from Hwy 403
- Maple Grove Plaza directly across the street
- Built out units available



FLOOR PLAN.....

AREA SUMMARY

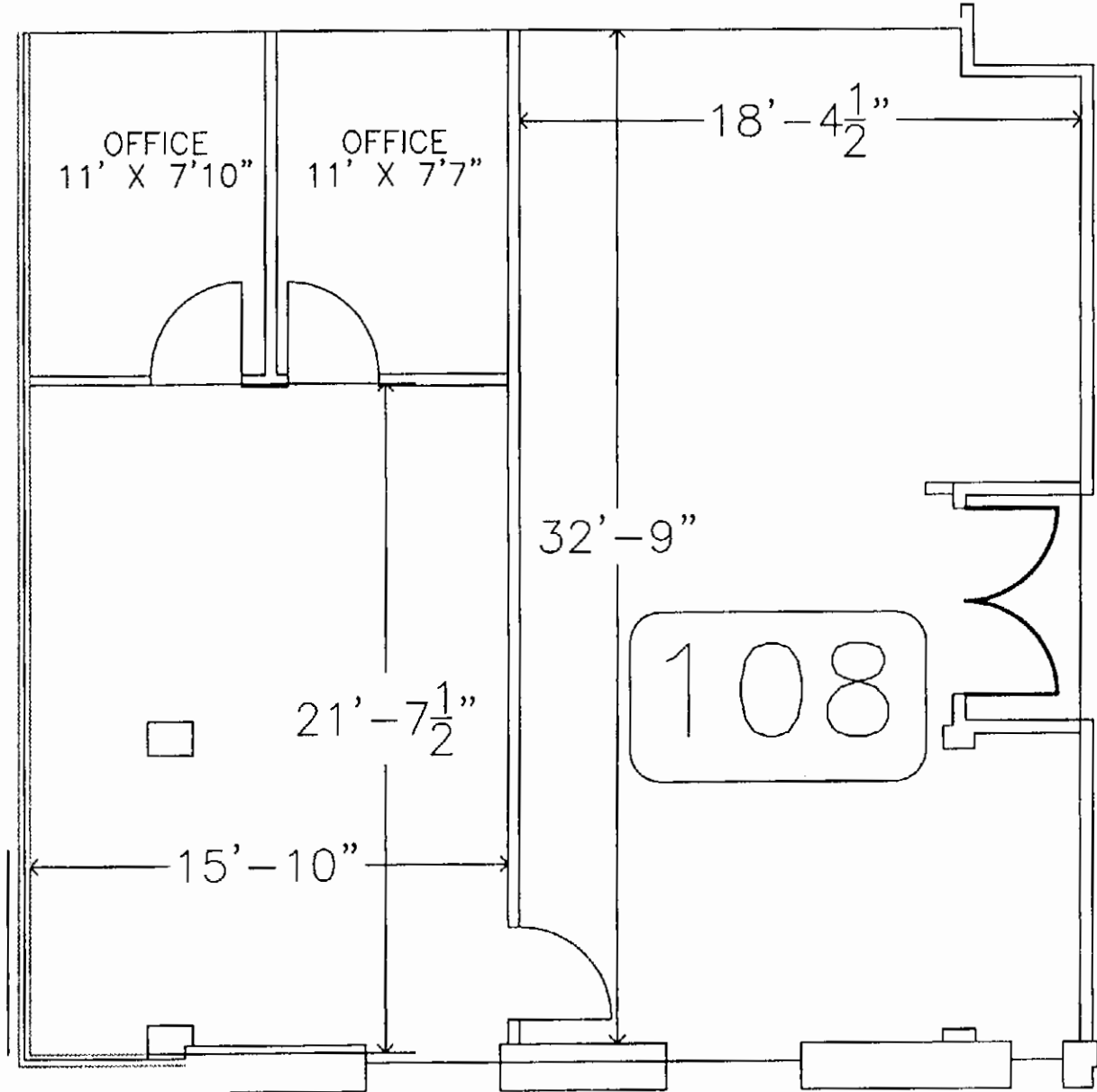

SUITE: **108**
RENTABLE AREA: **1,267 sf**
AVAILABLE: **Immediately**

FLOOR PLAN.....

AREA SUMMARY

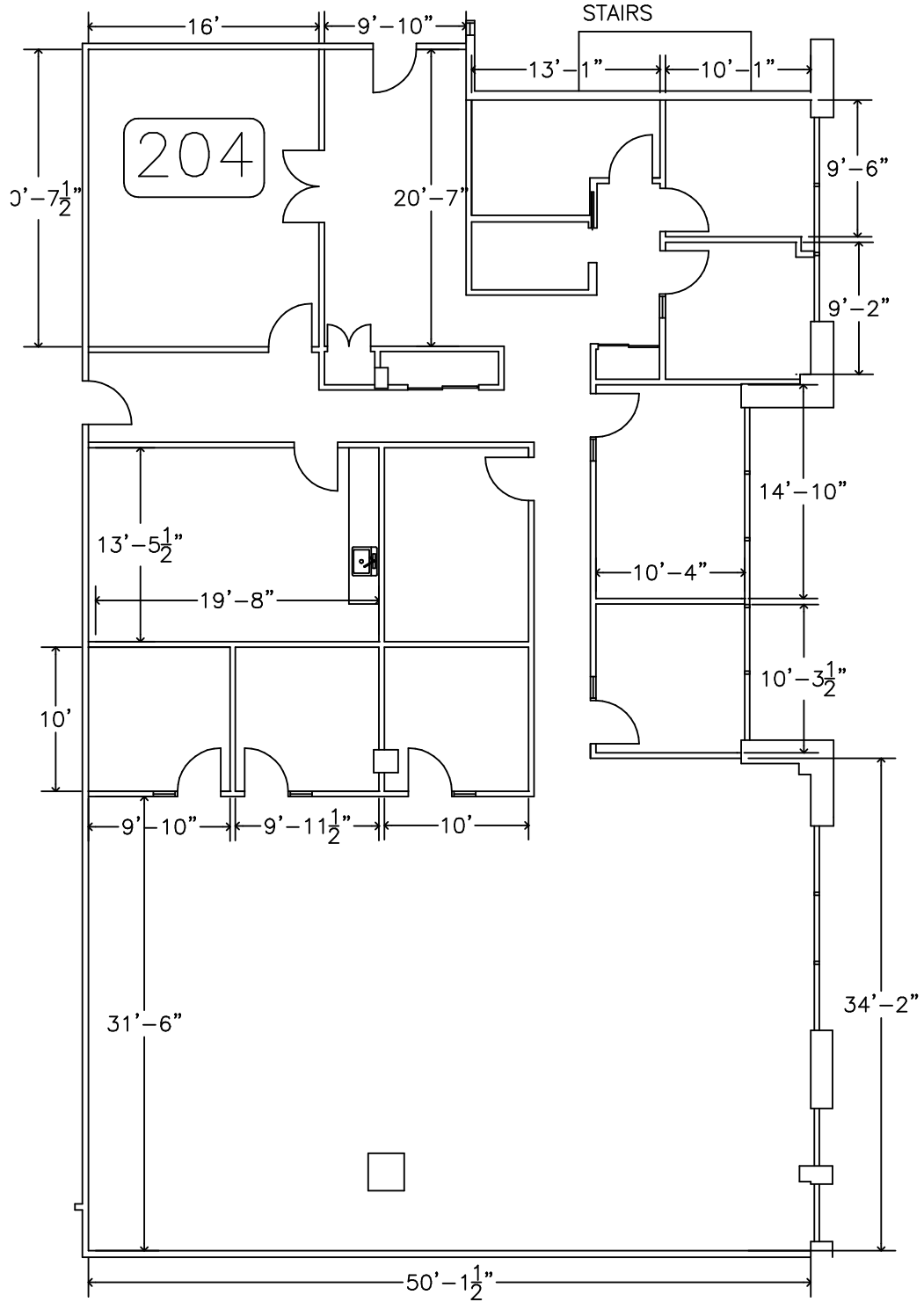

SUITE: **204**
RENTABLE AREA: **4,522 sf**
AVAILABLE: **Immediately**

FLOOR PLAN.....

AREA SUMMARY

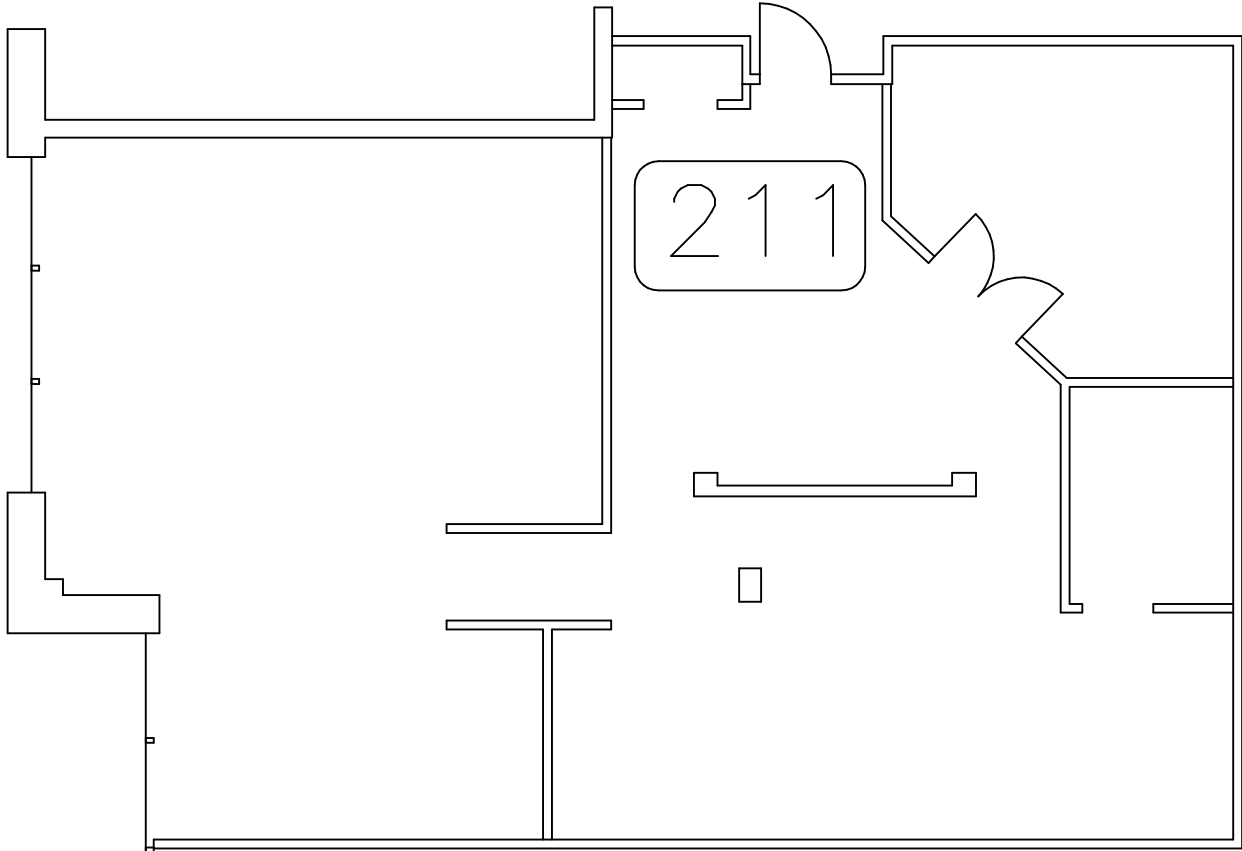

SUITE: **211**

RENTABLE AREA: **1,760 sf**

AVAILABLE: **Immediately**

FLOOR PLAN.....

AREA SUMMARY

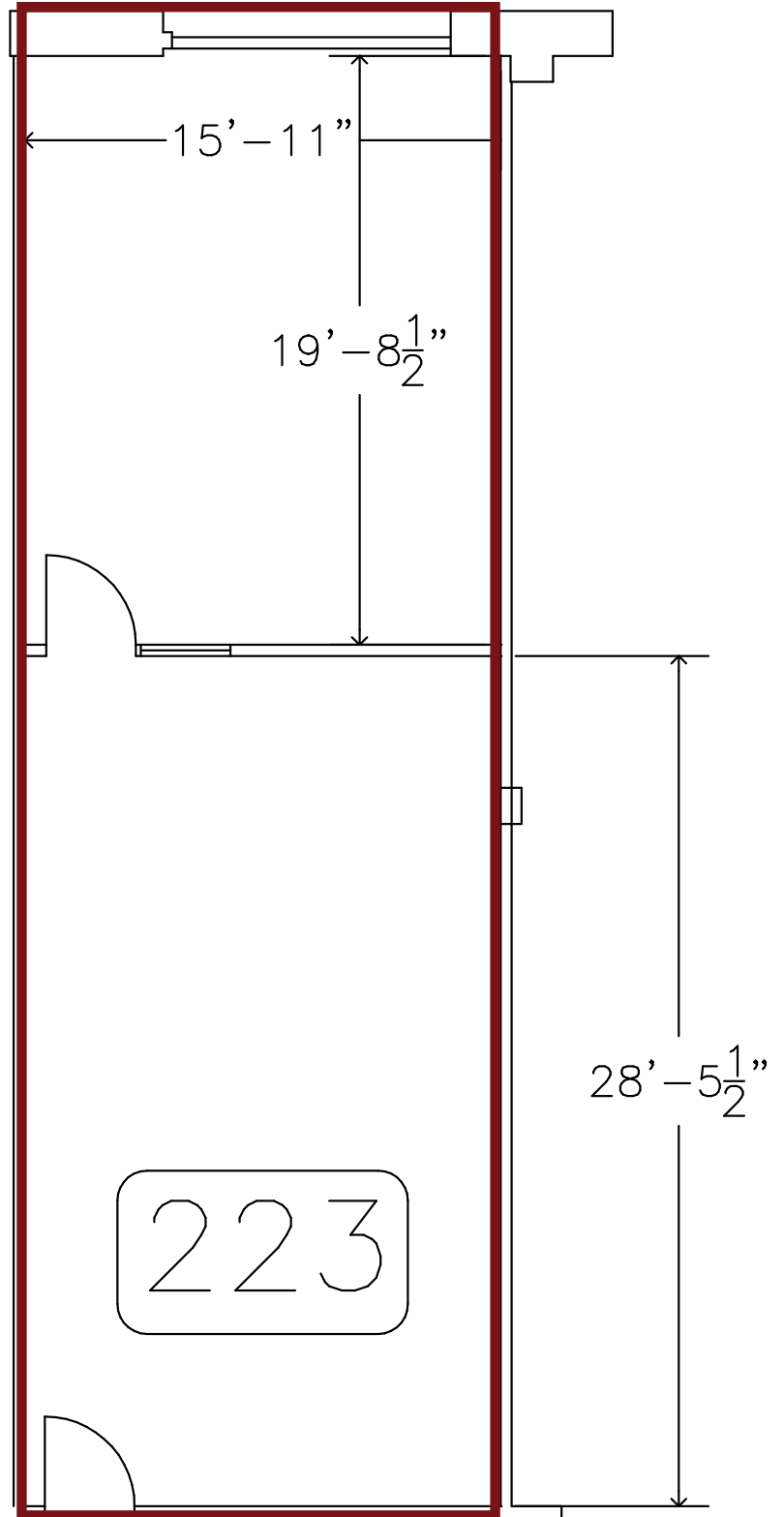

SUITE: **223**
RENTABLE AREA: **850 sf**
AVAILABLE: **Immediately**

PHOTOS

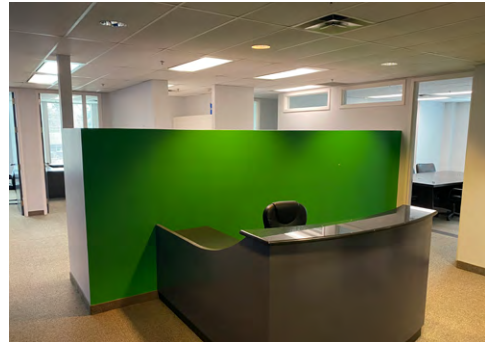

AMENITIES

WITHIN **10 KM RADIUS**



DRIVE TIMES

from 1540 Cornwall Road, Oakville, ON

- | | | | |
|--------------------|---------------------|--------------------|-----------------------|
| 9 MINS ... | Clarkson GO Station | 10 MINS ... | AMC Winston Churchill |
| 9 MINS ... | Oakville GO Station | 12 MINS ... | Highway 403 |
| 9 MINS ... | Oakville Place | 12 MINS ... | Sheridan College |
| 10 MINS ... | QEW | 12 MINS ... | Uptown Core |



186
RESTAURANTS

200
RETAILERS

166
FITNESS FACILITIES

96
HOTELS

106
BANKS

23
GAS STATIONS

CONTACT

AVISON YOUNG



Platinum member

Avison Young is one of the world's fastest-growing commercial real estate firms, and we are expanding globally. This growth is a testament to the commitment we've made to our clients and our employees. We're different. We've designed our organization to be highly collaborative and focused on one thing: creating the best solutions for our clients to deliver long-term success. And because of the value we deliver, our culture and our unique approach, clients and talent are joining us every day.

As further evidence of our unique model and success, Avison Young achieved Platinum status with the Canada's Best Managed Companies program in 2019 — our seventh consecutive year as a Best Managed company.

We will continue to expand and evolve, striving to meet the changing needs of our industry, our clients and our employees, but we will remain true to our values, culture and vision.



COMMERCIAL REAL ESTATE

Lisgar Commercial Real Estate was founded in 1956 by Martha Zenker. As a woman in the construction business she was immediately perceived to be at a disadvantage. Lisgar emerged and flourished because of her painstaking attention to detail, high quality products and relentless ambition. Today, Lisgar continues to distinguish itself by having dedicated and talented staff, our commitment to tenant service and producing unique and reliable environments.

To create professional working spaces, Lisgar collaborates with top-tier design firms and contractors. We enhance the feel and appearance of the building through continuous improvement and focused teamwork. We create efficient and clean office spaces.

Lisgar continuously invests in the properties for long term sustainability. We were founded with strong family values in mind and we strive to maintain this dynamic moving forward by developing long-term relationships with our tenants.

Lisgar is a commercial real estate company exclusively in Mississauga and Oakville. We have superior locations to enhance the success of your business no matter what stage you are in.

For more information, please contact:

Kurt Love, SIOR
Vice President, Sales Representative
905.283.2341
kurt.love@avisonyoung.com

Avison Young
Commercial Real Estate Services, LP, Brokerage
77 City Centre Drive, Suite 301
Mississauga, Ontario, Canada L5B 1M5
T 905.712.2100 F 905.712.2937
www.avisonyoung.ca

© 2023. Avison Young Commercial Real Estate Services, LP, Brokerage. Information contained herein was obtained from sources deemed reliable and, while thought to be correct, have not been verified. Avison Young does not guarantee the accuracy or completeness of the information presented, nor assumes any responsibility or liability for any errors or omissions therein.